

Safe installation of basketball rings

These Guidelines apply to the installation, safe use and maintenance of basketball rings and should be strictly adhered to in order to reduce the risk of accidental injury or death

1. Always tell children to **never hang or swing off the ring**
2. Dismantle any ring and backboard currently mounted on a single skin of brickwork - such as brickwork above a garage door
3. Do not fix any ring and backboard under any circumstances to a single skin of brickwork
4. Do not use any ring and backboard currently mounted on any brickwork until it has been checked for structural safety. If you plan to fix a ring and backboard to brickwork or any other structure, you should consult a structural engineer
5. A ring and backboard, under normal suburban type backyard conditions, should ideally be fixed to a hot dip galvanised steel post - 90mm x 90mm with a 5mm wall thickness would be adequate. The post should be set at least 800mm into a mass concrete footing 500mm x 500mm (or 500mm diameter) by 1 metre deep. Alternative systems can be provided by a structural engineer or by the equipment manufacturer

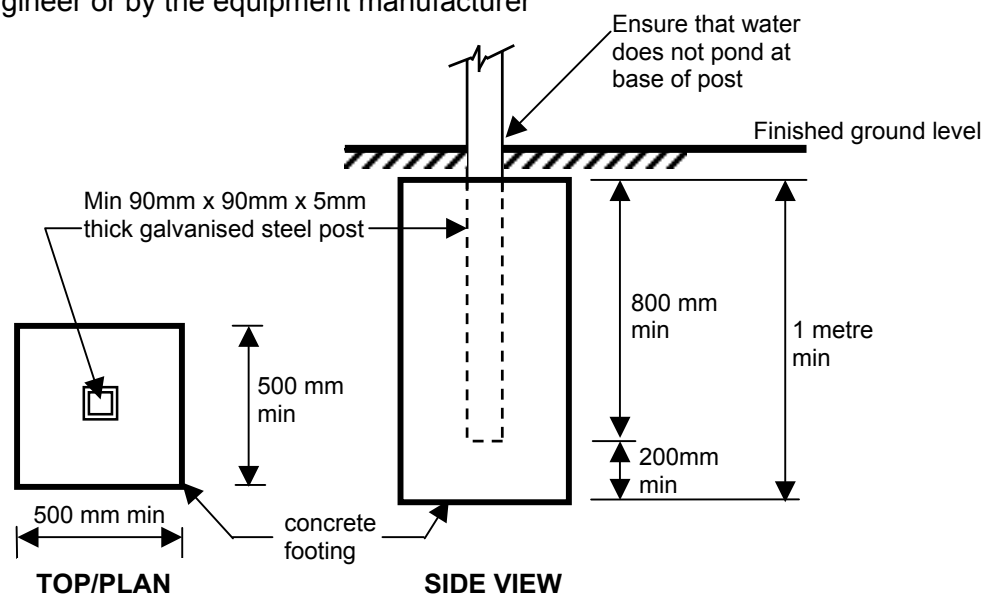

POST AND FOOTING DETAILS

6. Follow the manufacturer's instructions when attaching the basketball ring to the backboard, and the backboard to the post
7. Check the stability of a post, brick wall or any other supporting structure on a regular basis as it can deteriorate over time
8. Ensure that water does not pond at the post - footing connection, this is especially important in saltwater environments
9. If there is any doubt about the safety or stability of an installation, consult a structural engineer

These guidelines were developed with the assistance of:

- Acromat
- Archicentre
- Association of Consulting Structural Engineers of Victoria
- Basketball Australia
- Basketball Victoria
- Consumer Affairs Victoria
- Department of Tourism, Sport & Commonwealth Games
- IEAust
- Kidsafe
- Monash University Accident Research Centre
- Monash University Civil Engineering Department
- Municipal Association Victoria
- National Basketball League
- Victorian Local Governance Association
- Victorian Municipal Building Surveyors Group Inc

Need more information?

For further information relating to these guidelines go to:
www.buildingcommission.com.au click on “New Initiatives/Basketball Rings”

To find a structural engineer, search:
www.buildingcommission.com.au click on “Find an RBP”

For basketball safety information, call:
Basketball Victoria on (03) 9927 6666

Building Commission
Level 27, Casselden Place
2 Lonsdale Street, Melbourne
Victoria, Australia 3000
Telephone: 9285 6400
www.buildingcommission.com.au